

# 275/P 800A



## HYDRAULIC BOLLARD WITH BUILT-IN PUMP

PILOMAT 275/P 800A automatic bollards are the top line products of the PILOMAT range. Current models are the result of our 40 years' experience in the security field and in excess of 20 years in the specific design and manufacture of bollards. The 275/P 800A bollard is recommended for use in any pedestrian areas, private parkings, business parkings, private driveways, business driveways, commercial driveways.

The 275/P 800A is available with a large number of optional accessories that allow you to customize your system according to your security needs.



PAG.1/3

**PILOMAT**

100% MADE IN ITALY



PILOMAT s.r.l.  
www.pilomat.com / pilomat@pilomat.com  
Via Zanica 17/p, 24050, Grassobbio (BG) Italy  
Tel. +39.035.29.72.20  
Copyright 2016© Pilomat S.r.l. All rights reserved

275/P 800A\_DATASHEET.16 REVIEW 16/11/2016

## AVAILABLE ITEMS

PILOMAT BOLLARD 275/P 800AIXV - STAINLESS STEEL PAINTED
PILOMAT BOLLARD 275/P 800AIXS - STAINLESS STEEL BRUSHED
PIT IN ALUZINC FOR PILOMAT 275/P 800A - COUNTERFRAME AND BRACKETS ONE PIT FOR EACH BOLLARD
CONTROL UNIT FOR PILOMAT 275/P 800A
MULTILED FLASHING LIGHT- 25 LED POINTS
BUZZER ACOUSTIC SIGNAL FOR AUTOMATIC BOLLARD
REFLECTING ADHESIVE STRIP - WHITE (NO-LOGO)
HEAD WITHOUT LOGO FOR PILOMAT 275/P 800A
PAINTING WITH RAL COLOUR ON REQUEST
BIODEGRADABLE OIL FOR HYDRAULIC PUMP
HEATING RESISTANCE FOR PILOMAT BOLLARDS - TRANSFORMER AND THERMOSTAT ONE RESISTANCE FOR EACH BOLLARD
RADIO RECEIVER
RADIO TRANSMITTER TWO-CHANNEL
TRAFFIC LIGHT WITH TWO LIGHTS (GREEN-RED)
INDUCTIVE DETECTOR FOR LOOPS
INDUCTIVE LOOPS
TIMER PROGRAMMER
INDUCTIVE CARD READER
LOCK SELECTOR

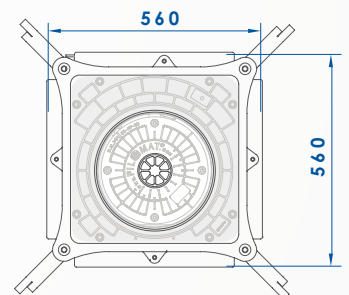
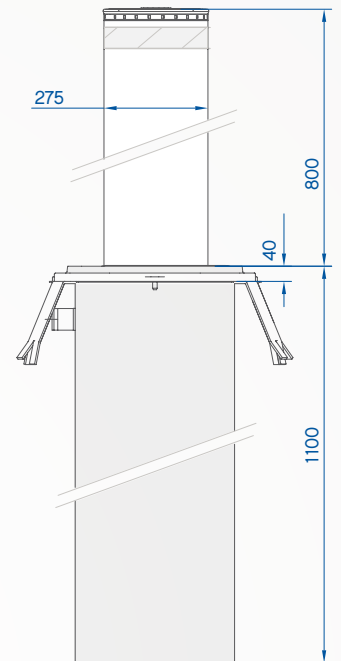

# 275/P 800A



MOVING CYLINDER	NORMAL STEEL FE370 - AISI 304 STAINLESS STEEL
MOVING CYLINDER DIAMETER	275mm
MOVING CYLINDER HEIGHT	800mm
MOVING CYLINDER THICKNESS - NORMAL STEEL	6mm
MOVING CYLINDER THICKNESS - STAINLESS STEEL	AISI 304: 6mm - AISI 316: 4mm
MOVING CYLINDER - NORMAL STEEL FINISH	ANTI-CORROSION TREATMENT - STANDARD PAINTING GREY ANTHRACITE
MOVING CYLINDER - STAINLESS STEEL FINISH	ANTI-CORROSION TREATMENT - STANDARD PAINTING GREY ANTHRACITE OR BRUSHED
MOVING CYLINDER - STAINLESS STEEL OTHER FINISHES	RIBS ON CYLINDER'S SURFACE
REFLECTING ADHESIVE STRIP	YES - HEIGHT 55mm
RISING SPEED	15cm/s
LOWERING SPEED	25cm/s
MANUAL EMERGENCY LOWERING	YES (ALSO FOR VERSION WITH AUTOMATIC LOWERING IF POWER FAILED)
SAFETY REVERSAL PRESSURE SWITCH	YES
CONNECTION LINE TO CONTROL UNIT	STANDARD 10m (MAX. LENGTH 80m - WITH HEATING RESISTANCE MAX. 50m)
VOLTAGE FOR CONTROL UNIT	230/400 Vac 50/60Hz
HYDRAULIC PUMP	BUILT-IN THE BOLLARD
PROTECTION CLASS	IP67
TYPE OF USE	INTENSIVE - LIFE AVERAGE 3.000.000 MOVEMENTS - 2000 MOVEMENTS/DAY
IMPACT RESISTANCE (WITHOUT DEFORMATION)	40.000 J
BREAKOUT RESISTANCE	250.000 J
OPERATING TEMPERATURE	-40 °C +70 °C (FOR TEMPERATURES LOWER THAN -10 °C USE THE HEATING RESISTANCE)

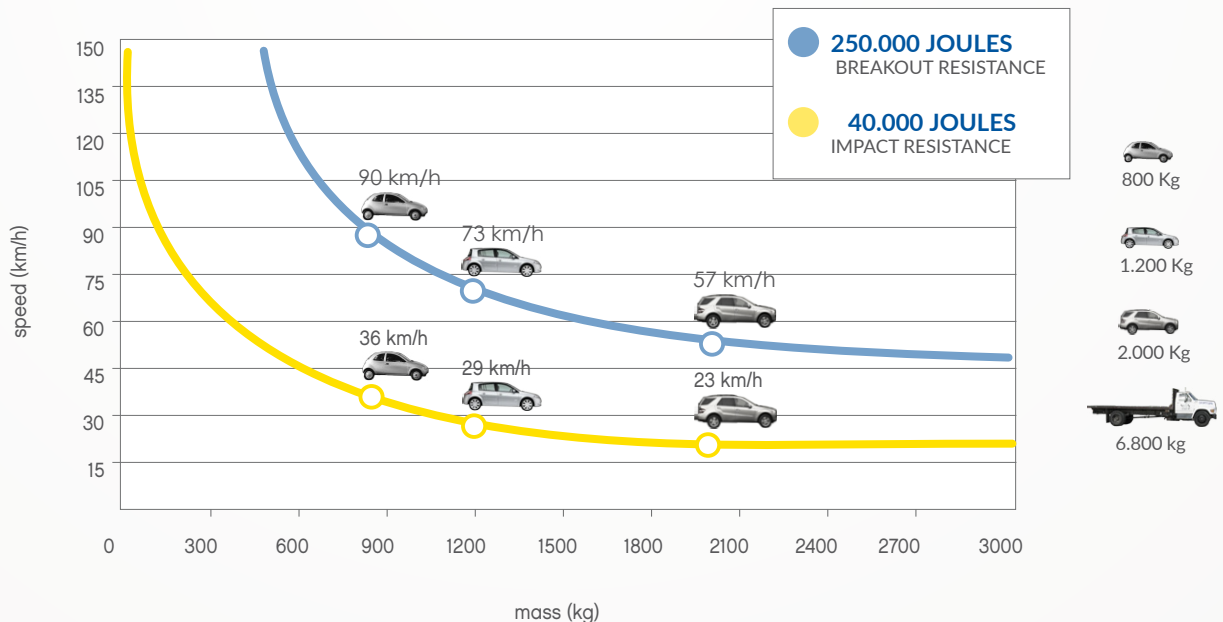

100% MADE IN ITALY

PILOMAT s.r.l.  
 www.pilomat.com / pilomat@pilomat.com  
 Via Zanica 17/p, 24050, Grassobbio (BG) Italy  
 Tel. +39.035.29.72.20  
 Copyright 2016© Pilomat S.r.l. All rights reserved