

# 275/M30FB 1200F



## ANTI-TERRORISM FIXED BOLLARDS WITH BASEMENT

The fixed 275/M30FB 1200F PILOMAT have been designed and built with architectural appearance similar to that of the retractable PILOMAT and therefore also allows the combined use of both versions.

Current models are the result of our 40 years' experience in the security field and in excess of 20 years in the specific design and manufacture of bollards.

### GENERAL FEATURES

The fixed antiterrorism PILOMAT are used to separate and prevent vehicles from breaching the perimeter of the following areas: Research Centres Embassies, Police Headquarters, Military Bases, Ministerial Buildings Sites in Sensitive Areas. These items are designed to ensure antiterrorism defence, and must be cemented into the ground at a depth that meets the standards of breakout resistance.



100% MADE IN ITALY

PAG.1/3

PILOMAT s.r.l.  
www.pilomat.com / pilomat@pilomat.com  
Via Zanica 17/p, 24050, Grassobbio (BG) Italy  
Tel. +39.035.29.72.20  
Copyright 2019© Pilomat S.r.l. All rights reserved

275/M30FB 1200F\_DATASHEET.19 REVIEW 10/09/2019

*Information in this document is for reference only. In pursuit of its policy of continuous refinement and improvement, Pilomat reserves the right to amend this information at any time and without prior notice.  
Picture shown is for illustration purpose only.*

# 275/M30FB 1200F



## AVAILABLE ITEMS

PILOMAT BOLLARD 275/M30FB 1200FFEVE - NORMAL STEEL PAINTED

PILOMAT BOLLARD 275/M30FB 1200FIXS - STAINLESS STEEL BRUSHED

RIBS ON FIXED CYLINDER - NORMAL STEEL

HEAD WITHOUT LOGO FOR PILOMAT 275/M30FB 1200F

REFLECTING ADHESIVE STRIP - WHITE (NO-LOGO)

MULTILED FLASHING LIGHT - 25 LED POINTS

FLASHING LIGHT POWER CIRCUIT FOR FIXED BOLLARDS (MAX. 4 BOLLARDS)

PAINTING WITH RAL COLOUR ON REQUEST

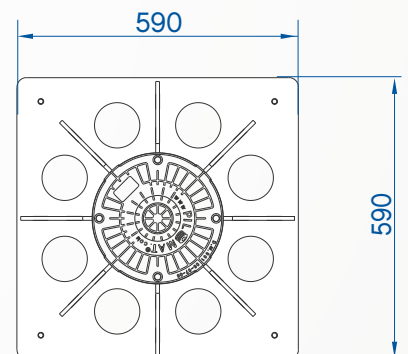
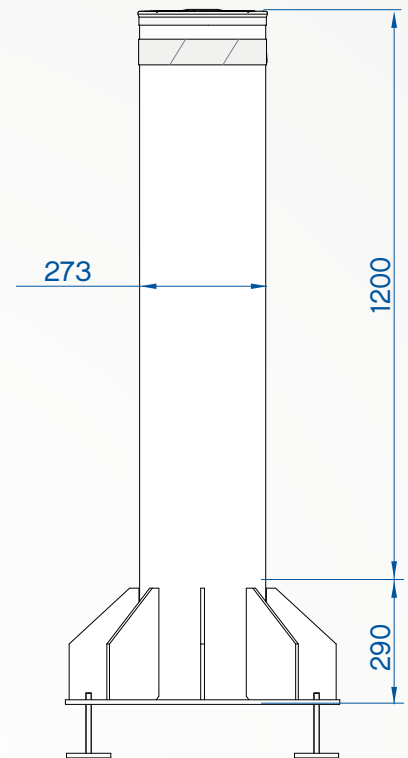

PAG.2/3

**PILOMAT**

100% MADE IN ITALY

PILOMAT s.r.l.  
www.pilomat.com / pilomat@pilomat.com  
Via Zanica 17/p, 24050, Grassobbio (BG) Italy  
Tel. +39.035.29.72.20  
Copyright 2019© Pilomat S.r.l. All rights reserved

275/M30FB 1200F\_DATASHEET.19 REVIEW 10/09/2019

Information in this document is for reference only. In pursuit of its policy of continuous refinement and improvement, Pilomat reserves the right to amend this information at any time and without prior notice.  
Picture shown is for illustration purpose only.

# 275/M30FB 1200F



FIXED CYLINDER MATERIAL	S355JR NORMAL STEEL - X5CrNi 18-10 (AISI 304) STAINLESS STEEL
FIXED CYLINDER DIAMETER - NORMAL STEEL	273mm
FIXED CYLINDER DIAMETER- STAINLESS STEEL	273mm
FIXED CYLINDER THICKNESS	1.200mm
FIXED CYLINDER THICKNESS	16mm
FIXED CYLINDER NORMAL STEEL FINISH	ANTI-CORROSION TREATMENT: METALIZATION GREY ANTHRACITE STANDARD PAINTING
FIXED CYLINDER STAINLESS STEEL FINISH	GREY ANTHRACITE STANDARD PAINTING OR BRUSHED
OTHER CYLINDER FINISH	RIBS ON CYLINDER'S SURFACE (NORMAL STEEL ONLY)
REFLECTING ADHESIVE STRIP	STANDARD - HEIGHT 55mm
CONNECTION LINE FOR FLASHING LIGHT (OPTIONAL)	STANDARD 10m (MAX. LENGTH 80m)
PROTECTION CLASS	IP67
IMPACT RESISTANCE (WITHOUT DEFORMATION)	700.000 J
BREAKOUT RESISTANCE	1.200.000 J

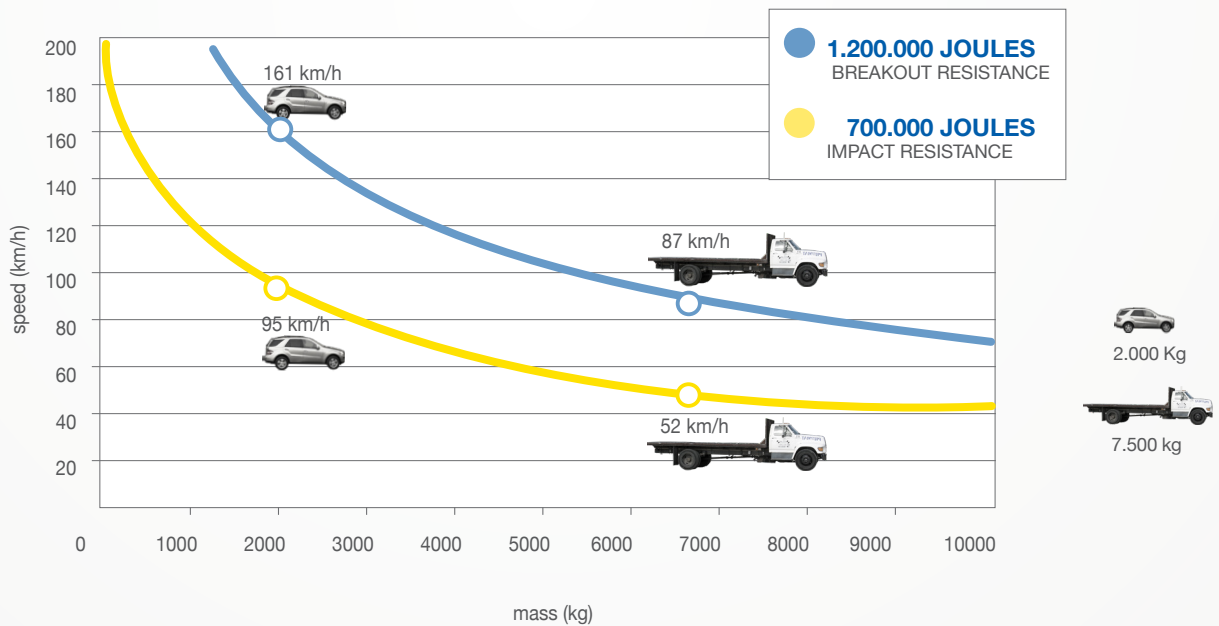

100% MADE IN ITALY