

The CHAIN is the new automatic barrier with moving chain with electromechanical movement to mark driveways and private parking places.

## GENERAL FEATURES

- large delimitation: The CHAIN allows the delimitation of areas up to 20m;
- linear and powerful moving: The CHAIN has two 24V motors (one in each column) that give to the chain a linear movement and allow to lift chains up to 8Kg;
- safe operation: The CHAIN is equipped with a impact analysis sensor to ensure the maximum safety in the operation;
- underground guide: an optional item is available (recommended) which consists of a U-guide to ground below the perpendicular of the chain, to allow the placing of the chain when lowered;
- operation in power failure: there is an additional item which is a power supply unit with battery accumulator to allow the temporary operation of the CHAIN in case of temporary power failure.



## AVAILABLE ITEMS

CHAIN 800 - EQUIPPED WITH CONTROL UNIT, RADIO RECEIVER AND 2 RADIO TRANSMITTERS (CHAIN NOT INCLUDED)

CHAIN IN S35JR DIAMETER 5mm - RED/WHITE (MAX. LENGTH 20m)

UNDERGROUND CHANNEL FOR CHAIN

KIT FOR TEMPORARY OPERATION IF POWER FAILED

MASTER CIRCUIT FOR CHAIN

SLAVE CIRCUIT FOR CHAIN

SLOWING DOWN AT COMPLETE OPENING AND CLOSING

RADIO RECEIVER

RADIO TRANSMITTER TWO-CHANNEL FOR CHAIN

CHAIN JOINT TO USE IN CASE OF BREAK

JUNCTION LINK CHAIN-SIDE COLUMNS

VOLTAGE FOR CHAIN	230/VAC 50HZ
TYPE OF MECHANISM	ELECTROMECHANIC WITH TWO GEAR MOTORS
GEAR MOTORS VOLTAGE	24Vdc
POWER ABSORPTION	24W - 1A
SIDE COLUMNS FINISH	ANTI-CORROSION TREATMENT - POLYESTER POWDER PAINTED - STANDARD GREY RAL 9006
CHAIN MAXIMUM LENGTH OF RED/WHITE CHAIN - LINK 5mm	20m - 8Kg
COLUMN DIMENSION	218x178x1010mm
CHAIN HEIGHT FROM GROUND LEVEL	10m: 680mm - 15m: 600mm - 20m:400mm
TYPE OF USE	INTERMITTENT (100 CYCLES/DAY)
OPENING TIME	10s
CLOSING TIME	10s

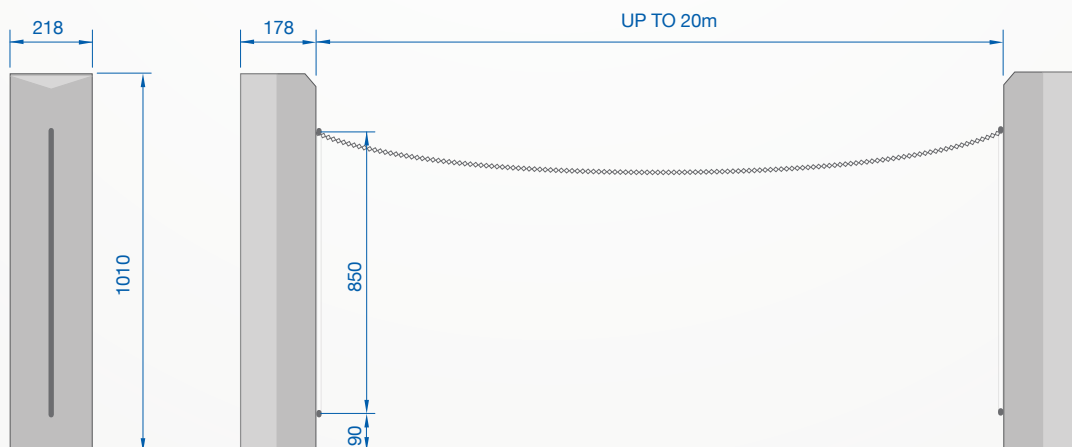

PAG.2/2